

## **MINERAL FERTILIZATION OF THREE MAIZE LINES OBTAINED BY IRRADIATING SEEDS OF THE EV 8728 VARIETY AT DALOA**

KONE KISSOMANBIEN<sup>1\*</sup>; SORO DOGNIMÉTON<sup>1,2</sup>; AYOLIE KOUTOUA<sup>1,3</sup>;  
GUEI MARTINEZ ARNAULT<sup>1,2</sup>; N'ZI AKHISSY CLOTILDE<sup>1</sup>  
AND KOUADIO YATTY JUSTIN<sup>1,3</sup>

Soil science, Agropedology, University Jean Lorougnon Guédé Daloa BP 150 Daloa, Côte d'Ivoire

DOI: <https://doi.org/10.51193/IJAER.2023.9502>

Received: 08 Aug. 2023 / Accepted: 29 Aug. 2023 / Published: 28 Oct. 2023

### **ABSTRACT**

Maize productivity has been declining sharply in recent years due to the effects of climate change and loss of soil fertility. Maize lines derived from the irradiation of EV 8728 display traits different from those of the parent variety. These new traits (lines 28; 67; 72) are evaluated in a mineral fertilization trial to characterize their mineral requirements. The lines were subjected to increasing doses of nitrogen (N0, 15; 30; 45; 60 and 90 kg/ha), phosphorus (P0; 10; 20; 30; 40 and 50 kg/ha) and potassium (K0; 20; 40; 60; 80; 110 kg/ha). Fertilization with simple N-, P- and K-based fertilizers did not reveal any obvious effect on growth parameters. However, N 15, P10 and K40 for growth, N 60, P30 and K40 for ear weight and N60 K40 for grain number gave the best results. Moreover, with the exception of the EV 8728 control, line 72 showed good growth and production indexes. These results could be improved by making a complete fertilization according to the basic fertility of the soil.

**Keywords:** Variety, Mineral fertilization, Line, Irradiation.

### **I. INTRODUCTION**

Maize (*Zea mays* L.) is the world's most widely grown cereal, with global production estimated at 1091 million tonnes in the 2019-2020 season. The global corn market is driven by the United States, Brazil, Argentina, Ukraine and, secondarily, South Africa [1]. In Africa, as of 2018, production is estimated at around 79 million tonnes for an area of 38,673,230 hectares [2]. In Côte d'Ivoire, national production rose from 1,025,000 tonnes in 2017 for an area of 523,538 ha to 1,006,000 tonnes, for a total sown area of 473,143 ha [2]. Nearly 50% of this production is located in the Savanes region in the north of the country [3].

Maize is the staple diet of rural populations in Côte d'Ivoire and most other West African countries. It is the most widely grown staple crop in sub-Saharan Africa, with over 33 million hectares planted each year [4]. It is used for human and animal feed (poultry, pigs, cattle) and as a raw material in certain industries (brewing, soap-making and oil production). Long considered a simple subsistence product, maize is now an agricultural commodity that is becoming increasingly important in Côte d'Ivoire, due to the growing economic stakes involved [5]. It is the most energetic cereal, thanks to its nutritional (rich in starch, protein and minerals) and economic advantages (easy to produce, harvest and store) [6]. However, despite its economic and nutritional importance, maize faces a number of problems, notably climate change, drought and soil impoverishment, all of which lead to a considerable drop in yield [7]. As maize is a very demanding crop in terms of mineral elements, it requires the use of fertile soils and good fertility management systems [8]. Nitrogen (N) contributes to the vegetative development of all above-ground parts of the plant and has a strong influence on yield, but only if other inputs and water requirements are met. According to [9], [10] estimates maize nitrogen requirements at 50 kilograms per hectare (kg/ha) for unimproved varieties and uncertain rainfall. These requirements rise with yield potential to 250 or 300kg/ha if yields of 12 t/ha or more can be expected. Nitrogen uptake by maize is slow at the start of growth, but accelerates with the appearance of male flowers, when uptake can exceed 4kg/ha/day ([11], in [9]). Phosphorus (P) is essential in the early stages of maize development, to ensure a good start to the crop [12]. Maize absorbs 80-90 kg/ha of phosphorus over the course of its cycle, but it is at the early stages of its development that it is most likely to suffer from deficiency. In practice, fertilization will range from 0 to 95 kg P<sub>2</sub>O<sub>5</sub>/ha for a yield of 10 t/ha in grain maize, and from 0 to 125 kg P<sub>2</sub>O<sub>5</sub>/ha for a yield of 15 t DM/ha in forage maize, with an average of around 30 to 40 units [12]. Like nitrogen, potassium (K) boosts crop development. In the plant, potassium is mainly found in the leaves and stalks, which explains why grain maize only exports 5.5 kg K<sub>2</sub>O/tonne and forage maize 11.9 kg K<sub>2</sub>O/tonne. In practice, fertilization advice will vary from 0 to 120 kg K<sub>2</sub>O/ha for a grain maize yield of 10 t/ha, and from 0 to 200 kg K<sub>2</sub>O/ha for a forage maize yield of 15 t DM/ha [12].

Deficiency of these nutrients, especially nitrogen, results in small, sickly plants with premature leaf senescence and low yields. These signs are sometimes confused with a lack of water. [13].

This justifies the interest in researching maize varieties that are tolerant to the low availability of mineral elements in the soil. The aim of the study is to test the N, P and K requirements of 3 fifth-generation maize lines obtained by irradiating seeds of the EV 8728 variety with gamma radiation, since irradiation is likely to cause mutations to produce lines with desirable traits. More specifically, the aim is to determine:

- the response of three lines to different levels of N, P and K fertilization,

- and the most tolerant line to low availability of each of the elements N, P and K.

## **II. MATERIALS AND METHODS**

### **2.1. Plant material**

It is essentially composed of maize seed. Three lines L28, L67 and L72 have been selected. These lines are the result of a series of self-fertilisation of plants obtained after irradiation of the seed of the EV 8728 variety. Irradiation consists of exposing seeds to a flow of ionising radiation which causes mutation. Mutation is a change in hereditary material that occurs in living organisms. It is a basic change in the genetic heritage of the species. Mutation provides new material for the production of new lines and tools for identifying new genes [14]. This method could give rise to interesting new traits. The non-irradiated variety EV8728 was also used as a control.

### **2.2. Fertilizers**

The fertilizers used in this study are all simple fertilizers. They are :

- Urea formulated at 46% N
- Triple Superphosphate TSP formulated at 45% P<sub>2</sub>O<sub>5</sub>
- Potassium chloride, KCl (K<sub>2</sub>O 60%)

### **2.3 Methods**

#### **2.3.1. Experimental set-up**

The experimental set-up used is a randomized block design. The plot consists of two blocks of 12 lines each for the three lines (L1, L2, L3) and the control (EV8728). The sub-blocks are composed of 6 lines each, with three lines corresponding to three treatments for one line. The lines are subdivided into 6 compartments of 10 bins each (6 mineral treatments). The spacing between stakes for the same treatment is 0.2 m and 0.4 m from one treatment to another, with 1 m between lines. We carried out a replacement semi for seeds that failed to germinate.

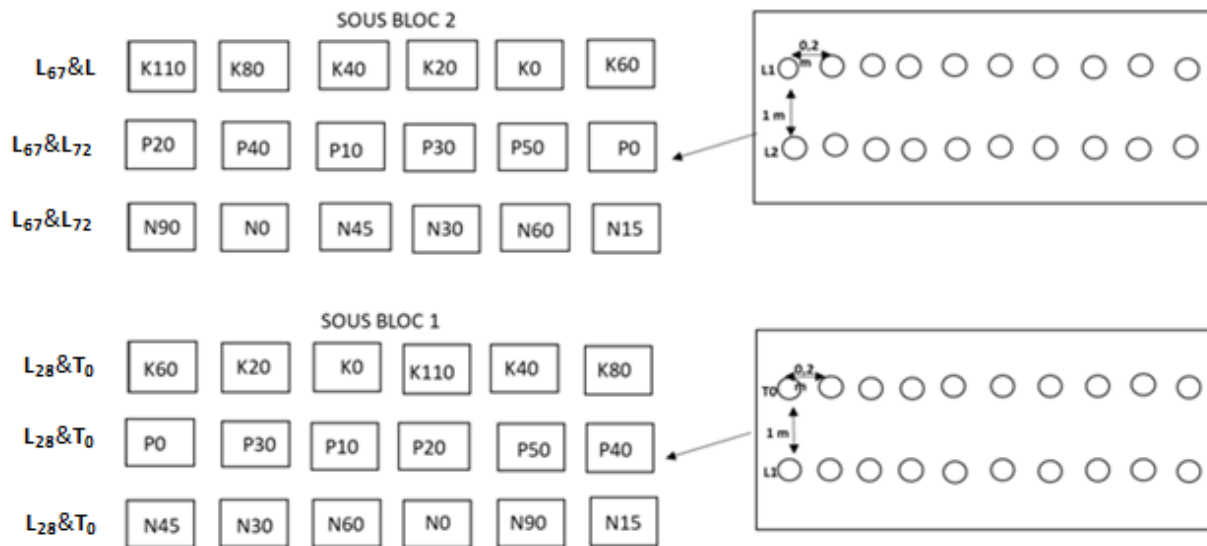

**Figure 1: Experimental set-up**

N0 = 0 kg/ha ; N15 = 15 kg/ha ; N30 = 30kg/ha ; N45 = 45kg/ha ; N60 = 60kg/ha ;

N90 =90 kg/ha.

P0 = 0 kg/ha ; P10 = 10 kg/ha ; P20 = 20 kg/ha ; P30 = 30 kg/ha ; P40 =40 kg/ha ;

P50 = 50 kg/ha.

K0 = 0 kg/ha ; K20 = 20 kg/ha ; K40 = 40 kg/ha ; K60 = 60 kg/ha ; K80 = 80 kg/ha ;

K110 = 110 kg/ha.

### 2.3.2. Fertilization

The elements N, P and K are applied at different times and in variable doses in pots at the foot of the plant. The first dose of phosphorus (P) and the first half-dose of potassium (K) are applied 18 days after sowing. Nitrogen (N) is applied one week after the first two elements, i.e. 25 days after sowing. The second half-dose of potassium (K) is applied at 40 days after sowing, and that of nitrogen at 47 days after sowing. The application rates for the various elements in kg.ha<sup>-1</sup> are:

N : 0 - 15 - 30 - 45 - 60 - 80;

P : 0 - 10 - 20 - 30 - 40 - 50 ;

K : 0 - 20 - 40 - 60 - 80 - 110.

### 2.3.3. Data collection

Measurements were carried out on 8 randomly selected plants in each compartment. Eleven (11) traits selected from the maize descriptors (IPGRI, 1991) were retained. These are:

- Final plant height: measured in cm using a metal tape measure from the collar to the base of the panicle leaf.
- Ear insertion height: measured in cm using a tape measure from the collar to the ear insertion node
- Diameter at collar: consists in measuring the diameter of the maize plant at the collar using a caliper. It is measured in millimeters (mm).
- Total number of leaves: determined by counting from the first leaves at emergence to the panicle leaf at flowering.
- Female flowering: the time to female flowering is expressed as the number of days after sowing between the sowing date and the date on which the silk is observed.
- Male flowering: this is reached when 50% of the plants in the plot have released pollen. The time to reach flowering is expressed in days after sowing (DAS).
- Number of ears of corn: consists of counting the number of ears of corn on each plant;
- Mass of cob with spathe; Mass of cob without spathe: The mass of the cob with and without spathe is obtained in grams (g) by weighing the cob with spathe first and then after despathe using an electronic balance;
- Number of grains per ear: The grains in three (3) randomly selected rows on the ear are counted and the average (M) calculated. The number of grains per ear is the product of the number of rows and the average number (M) of grains per row.

$$NG=M \times nR$$

## **2.4. Statistical analysis**

A descriptive analysis of the data was carried out on the averages obtained, followed by an analysis of variance (ANOVA) using XLStat 2014 software. The analysis of variance will enable a comparative study of the different means obtained. In addition, a correlation test is performed between vegetation and production parameters when a significant difference is observed. The significance of the test is determined by comparing the probability (P) associated with the test statistic with the theoretical value  $\alpha= 0.05$ . When  $P \geq 0.05$ , we deduce that there is no difference between the means. On the other hand, when  $P < 0.05$ , there is a significant difference.

## **III. RESULTS AND DISCUSSION**

### **3.1 Results**

#### **3.1.1. Overall characteristics of fertilized lines**

The overall description of the data collected is given in Table I. Analysis of the table reveals a low coefficient of variation (< 20%) for most of the variables measured, namely number of spikes per plant, neck circumference and number of leaves, with respective variance values of 0.012; 10.62 and 2.58. However, it is high for final height and spike parameters (number of grains per spike, spike mass with spathes and spike mass without spathes). On the other hand, significant differences were recorded between minimum and maximum values for all traits. Maize plant height ranged from 55 to 303 cm, with an average of 178.19 cm and 12 to 24 leaves, with an average of 18, depending on variety and level of fertilization. From this size, an average panicle height of 6 to 55 cm can be deduced, depending on lineage and fertilizer dose. Male and female flowering took place at an average of 62 and 63 days respectively, generally forming one ear per plant. Spike weight without spathe varied from 3.6 to 276.2 g.

**Table I: Overall characteristics of the lines studied**

Variables	Number	Minimum	Maximum	Mean standart	Deviation	Variance
NEPI	1151	1	2	1,01	0,1097	0,012
DIAC	1151	6,63	26,13	14,30	3,25854	10,618
NFeuilfin	1151	12	24	18,74	1,6046	2,575
HEPILLET	1151	6	55	29,66	7,416	54,997
HIE	1150	10	142	59,93	17,035	290,193
FLOM	1151	46	79	62,67	6,7825	46,002
FLOF	1151	44	79	63,09	7,4061	54,851
MEPI	1151	3,6	276,2	89,01	39,6392252	1571,268
MEPIS	1151	13,4	301,7	99,97	42,5954145	1814,369
HPLfin	1151	55	303	178,15	33,3324	1111,052
NGREPI	1151	4	766	293,132	113,7203	12932,316

HPLfin: final plant height; HIE: ear insertion height; DIAC: Diameter at crown; NFeuilfin : total number of leaves; FLOF: female flowering; FLOM: male flowering; NEPI: number of spikes; MEPIS: spike mass with spathe; MEPI: spike mass without spathe; NGREPI: number of grains per spike; HEPILLET: spikelet height.

### 3.1.2. Agromorphological characterization of the lines studied.

The agromorphological characteristics of the different maize lines are shown in Table II. Statistical analysis revealed a highly significant effect ( $p < 0.001$ ) for all the parameters studied, with the exception of the number of ears (Nepi), where no significant effect was observed. The values of the various agromorphological parameters differ from one line to another. The highest final plant height (191.3 cm), ear insertion height (63 cm), spikelet size (33.3 cm) and collar diameter (15.7 mm) were recorded for the parent variety EV 8728. The line (L67) had the highest final number of leaves (19.6). Moreover, EV8728 was earlier than the other lines, with a female

flowering date equal to 57.7 days after sowing. On the other hand, line 67 flowered faster than the others (62.5 days after sowing). Furthermore, the highest ear weight with spathe (122.8 g), ear weight without spathe (110.9 g) and number of grains per ear (348.2 grains) were obtained with EV8728. Lines 72 and 67 came in second with production values just below the control (EV8728).

### **3.1.3. Correlation between studied parameters**

To establish possible relationships between the various parameters measured during this study, a correlation matrix was drawn up (Table III). Analysis of this matrix showed that the number of grains per spike (NGREPI) showed a strong positive correlation with spike mass with or without spathe ( $r = 0.822$  and  $r = 0.824$ ). On the other hand, no correlation was found between the number of grains per spike and parameters such as plant height, panicle size, spike insertion height, neck circumference, number of leaves, number of spikes and flowering time. Spike masses with and without spathe were strongly positively correlated ( $r = 0.989$ ). Also male and female flowering times showed a strong positive correlation ( $r = 0.914$ ). The analysis also showed average correlations between neck circumference and the parameters final height ( $r = 0.536$ ) and ear insertion height ( $r = 0.554$ ). Height of ear insertion (HIE) showed a strong positive correlation with final plant height (HPLfin) ( $r = 0.722$ ). Only female flowering time and neck circumference had a mean negative correlation ( $r = -0.503$ ).

**Table II: Some characteristics of the lines studied**

Lines	Hplfin	Hepillet	HiE	Diac	NFeuilles	Flofem	Flomal	NEpi	MEpis	MEpi	NGrEpi
<b>L72</b>	184,7±37,1c	26,7±7,8a	58,1±16,4b	13,1±3,0a	18,6±1,6a	64,0±6,4c	64,8±5,9c	1,0±0,08a	97,2±35,9b	85,9±32,6b	261,8±86,5a
<b>L28</b>	173,5±25,2b	28,7±14,2b	65,5±14,2c	14,1±2,6b	18,5±1,5a	68,1±6,9d	66,1±6,9d	1,0±0,1a	78,5±36,2a	68,9±34,4a	251,3±99,1a
<b>L67</b>	163,2±33,0a	30,1±7,2c	53,2±15,6a	14,4±3,3b	19,6±1,4b	62,5±6,0b	62,5±5,1a	1,0±0,1a	101,5±43,1b	90,4±40,2b	311,4±108,4b
<b>EV8728</b>	191,3±29,8d	33,3±6,3d	63,0±19,0c	15,7±3,6c	18,3±1,6a	57,7±6,4a	64,0±5,5b	1,0±0,2a	122,8±42,7c	110,9±39,1c	348,2±128,2c
<b>CV</b>											
<b>P-value</b>	<0,001	<0,001	<0,001	<0,001	<0,001	<0,001	<0,001	0,177	<0,001	<0,001	<0,001

In the same column, means followed by the same letter are significantly identical at the 5% threshold (-Newman-Keuls) Hplfin: final plant height; HiE: ear insertion height; Diac: Diameter at crown; NFeuilles : total number of leaves; FloFem: female flowering; Flomal: male flowering; NEpi: number of spikes; MEpis: spike mass with spathe; MEpi: spike mass without spathe; NGrEpi: number of grains per spike; Hepillet: spikelet height.

**Table III: Correlation between measured parameters**

	HPLfin	Hepillet	HIE	DIAC	NFeuil	FLOF	FLOM	NEPI	MEPIS	MEPI	NGREPI
<b>HPLfin</b>	1										
<b>HEPILLET</b>	0,487	1									
<b>HIE</b>	<b>0,722</b>	0,288	1								
<b>DIAC</b>	<b>0,536</b>	0,427	<b>0,554</b>	1							
<b>NFeuilfin</b>	0,353	0,159	0,353	0,322	1						
<b>FLOF</b>	-0,425	-0,33	-0,288	<b>-0,503</b>	-0,121	1					
<b>FLOM</b>	-0,351	-0,33	-0,221	-0,49	-0,054	<b>0,914</b>	1				
<b>NEPI</b>	-0,041	-0,009	-0,003	0,033	0,003	-0,016	-0,01	1			
<b>MEPIS</b>	0,0099	0,133	0,006	0,1	-0,034	-0,233	-0,207	0,212	1		
<b>MEPI</b>	0,0097	0,132	0,001	0,105	-0,035	-0,237	-0,215	0,211	<b>0,989</b>	1	
<b>NGREPI</b>	0,068	0,158	0,008	0,138	-0,011	-0,257	-0,254	0,178	<b>0,822</b>	<b>0,824</b>	1



**3.1.4 Effect of fertilizer doses on studied parameters**

- Final plant height

Analysis of plant height gave variable values depending on the level of fertilizer applied (Fig 2).

For potassium (K), at 40 kg.ha<sup>-1</sup> (K40), we had the greatest height, with an average of 187.2 cm. The lowest height (168.9 cm) is obtained without fertilizer (K0). Plants fertilized with K20, K60, K80 and K110 give more or less equal intermediate heights (173.3 cm to 180.2 cm respectively).

In terms of nitrogen (N), the 60 kg and 30 kg fertilizers produced the shortest plant heights, at 169.1 cm and 169.3 cm respectively, while N15 and N0, with average plant heights of 181.7 cm and 180.8 cm, produced the tallest plants.

With phosphate fertilization (P), the P0 control developed the smallest plants (176.1 cm), while P10 produced the tallest plants (193.5 cm). The other fertilization levels P20 (182.9 cm); P30 (180.9 cm); P40 (183.8 cm) and P50 (184.5 cm) have intermediate values.

The greatest height is obtained under phosphate fertilization (193.5 cm with P10), while the smallest heights are obtained from the control without fertilizer (168.9 cm) and nitrogen fertilization.

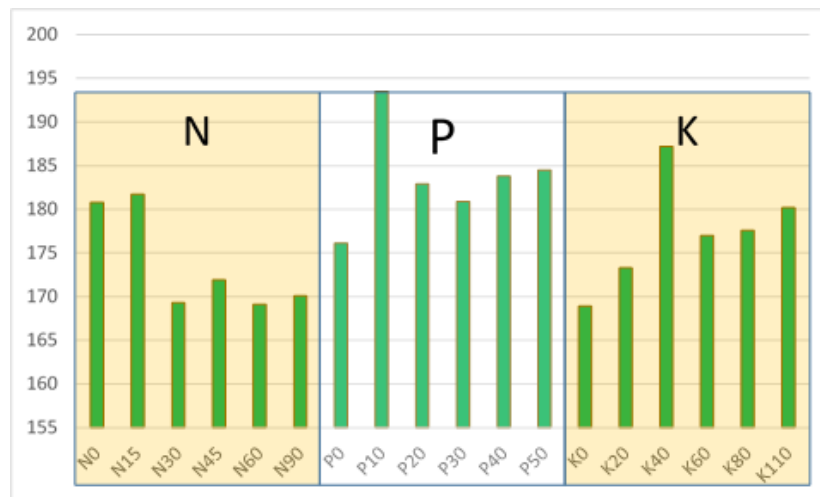

**Figure 2: Variation in plant height according to fertilization level**

Corn plant collar diameter varies with fertility level. For potassium and nitrogen, values vary between 13 mm and 14.6 mm. K40 (14.6 mm); K80 (14.5 mm); N15 (14.3 mm) and N90 (14.3 mm) give the largest diameters. Phosphorus values range from 13mm to 16mm. The smallest diameter is given by the P0 control with an average of 13.8 mm. P10 (16.4 mm) and P50 (16 mm) have the largest diameters.

**- Number of leaves**

The number of leaves varies between 18 and 19 (P10 and K40).

**- Female flowering**

In terms of potassium, the time to female flowering varies around 64 days after sowing. K40 (62.3 d) gave the shortest delay. For nitrogen, the analysis revealed several results. The shortest flowering time was given by N90 (53.1 d). The longest was N30 (64.8 d) and N60 (64.8 d). For phosphorus, the analysis gave values that were apparently equal in pairs. The shortest flowering times were P10 (59.2 d) and P20 (59.6 d), and the longest were P0 (62.6 d) and P30 (62.0 d). P40 and P50 gave 61.2d and 61.7d respectively.

**- Male flowering**

For male flowering, the analysis yielded values ranging from 59 to 65 days. For potassium, K40 (61.6 d) gives the shortest flowering time and K110 the longest, with an average of 65.1 d. For nitrogen, N90 (64.4 d) has the longest flowering time and N15 (61.4) the shortest. For phosphorus, P10 (59 d) and P20 (60.4 d) gave the shortest and longest flowering times respectively.

**- Inter-flowering time**

Knowing the flowering dates enabled us to calculate the time interval between male and female flowering. This interval varied between 1 and 2 days (Fig 3). Female flowering seemed to be delayed by high N and P doses, while high K doses had no impact.

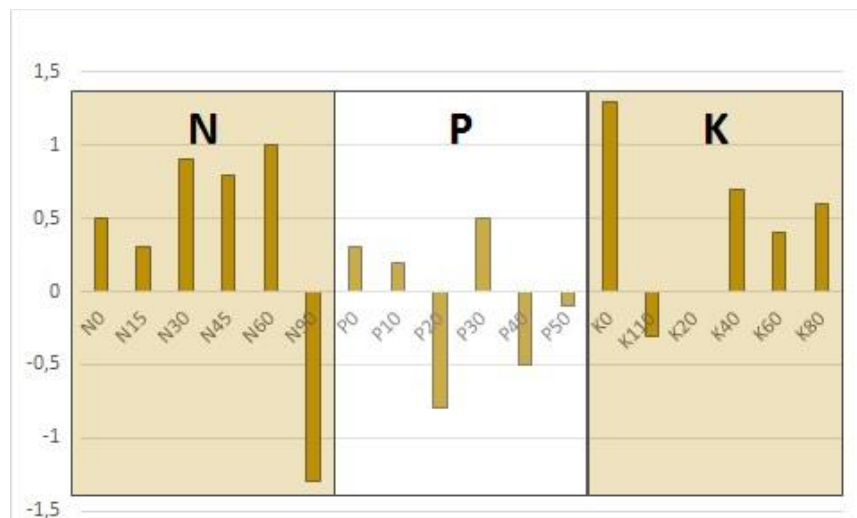

**Figure 3: Variation in inter-flowering time**

**- Number of ears**

At this level, the analysis showed that there was a majority of one (1) spike per plant, with standard deviations varying between 0 and 1.2.

**- Ear mass with spathe**

The analysis yielded various results. In terms of potassium, the K0 control (77.0 g) had the lowest mass. K40 had the highest mass, with an average of 129.3 g. The others give intermediate values that are more or less close to the control, with the exception of K20 (122.9 g), which gives an average slightly close to that of K40. In terms of nitrogen, the control N0 (88.4 g) also has the lowest mass. N60 (118.4 g) has the highest mass. The others tend progressively towards N60. As for phosphorus, P0 (control) and P30 give the highest mass with an average of  $108.9 \pm 44.5$ g and  $108.5 \pm 39$ g respectively. Whereas P20 (83.9g) gives the lowest mass. P10 (99.5 g), P40 (101.3 g) and P50 (99.5 g) have a lower average than the control.

**- Spatheless ear mass**

The spathe-free ear masses of the different doses studied show a variation in the mean spathe-free ear mass (Figure 3). The highest average (116.6 g) was recorded with 40 kg.ha<sup>-1</sup> potassium (Fig 4C). In terms of nitrogen, 60 kg.ha<sup>-1</sup> produced the highest average mass per ear (107.4 g). Moreover, ear mass increased progressively to reach this maximum before decreasing despite the increased dose (Fig 4A).

When fertilizing with potassium, average ear mass increased progressively with dose, reaching a maximum at 40 kg (Fig 4C).

**- Number of grains per ear**

The number of grains per ear obtained by this analysis is variable. However, under N or K fertilization, the average number of grains increases with the dose, reaching a maximum at 335 and 366 respectively for N (fig 5A) at 60 kg.ha<sup>-1</sup> and K (fig 5C) used at 40 Kg.ha<sup>-1</sup>. This variation in the average number of grains is less dependent on the P dose used (fig 5B).

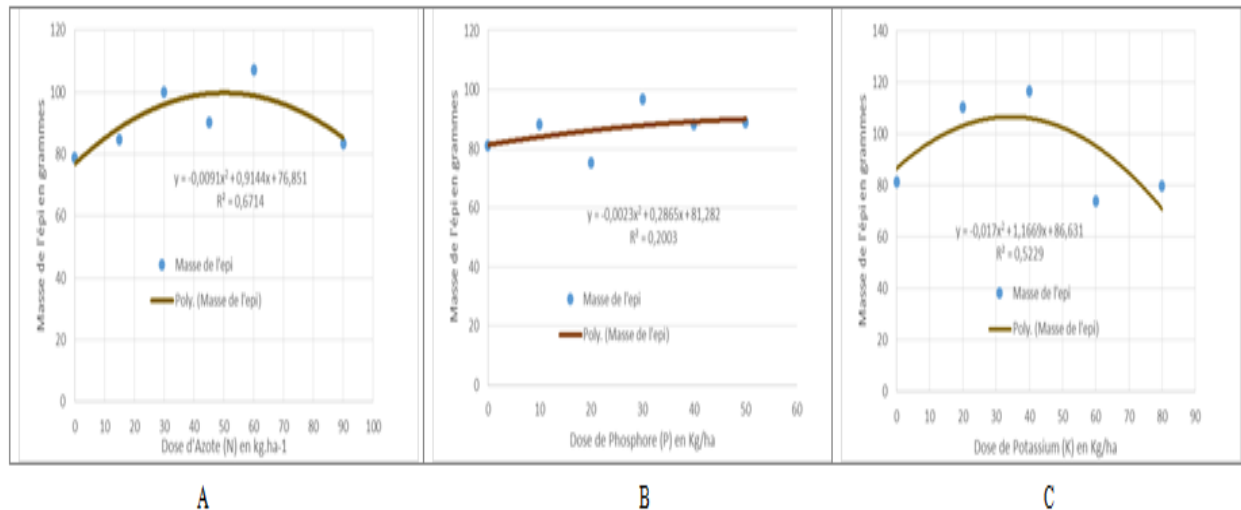

Figure 4: Variation in spike mass without spathes

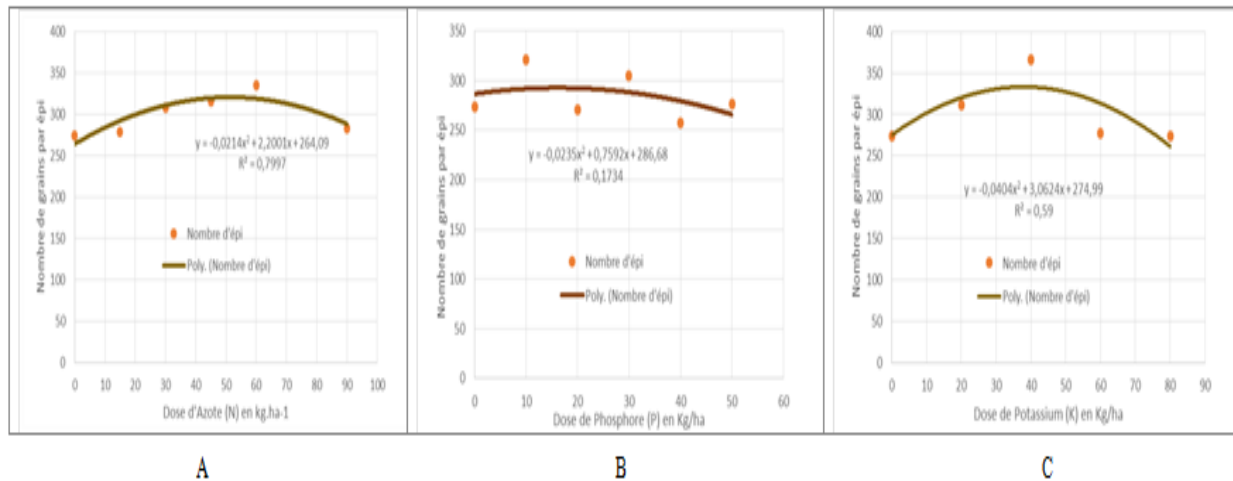

Figure 5: Variation in the number of grains per ear

### 3.2. Discussion

The study focused on the agromorphological characterization of maize lines resulting from gamma irradiation of seeds of the EV8728 variety. In order to study the behavior of each line under varying doses of N, P and K fertilizers, various parameters were evaluated.

Descriptive analyses showed significant variations between minimum and maximum values for all morphological traits analyzed. These variations confirm the transmission of changes in

irradiated seeds to successive generations of plants, and the diversity of these mutations. In fact, irradiation may have caused changes in the genetic material (DNA) of the EV8728 variety.

### **3.2.1. Growth parameters**

The results showed a reduction in growth parameters due to irradiation. Indeed, plant height, ear insertion height, panicle size and crown circumference of the EV8728 mother variety were the highest. These results are similar to those of [15], who explain that gamma radiation significantly reduces growth parameters in *Lepidium sativum*. Some authors, such as [16], show that gamma irradiation doses significantly reduce growth parameters in common wheat. According to the author, this reduction in growth could be linked to the deleterious effect of gamma rays on cell structure and biochemical reactions. Similarly, for parameters such as ear mass and number of grains per ear, the parent variety EV8728 showed the best results, ahead of the irradiated lines. The number of seeds from irradiated plants is significantly lower than that of the control (EV8728).

The analysis showed variability in plant response to fertilization. When N, P and K were applied separately, an effect was observed at low N, P and K doses. Indeed, the largest sizes are obtained with 15 Kg.ha<sup>-1</sup> N, 10 Kg.ha<sup>-1</sup> P and 40 Kg.ha<sup>-1</sup> K. These results reflect an already satisfactory level of basic soil fertility ([17] and [18]).

In fact, the soil analysis reinforces the good level of basic fertility of the soil at the test site. Moreover, [19] confirms that the large plant size observed on plots fertilized with high doses of mineral fertilizers is more related to the quantity of nitrogen available. Above these doses, the additional quantities applied resulted in a reduction in size for nitrogen, phosphorus and potassium alike.

### **3.2.2. Production parameters**

The number of maize kernels and cob mass increased with increasing fertilizer doses, more specifically for nitrogen and potassium, reaching maximum useful doses of 60 Kg.ha<sup>-1</sup> and 40 Kg.ha<sup>-1</sup> for nitrogen and potassium respectively. These results are similar to those of [20] who, in his experiment on the effect of nitrogen on maize yields, showed that increasing nitrogen doses significantly increased maize yields. In the experiment, nitrogen appeared to be the element that most favored an increase in production parameters, albeit in the presence of sufficiently available P and K. These results corroborate those of [21], who showed that nitrogen limitation is the main constraint to cereal production in sub-Saharan Africa. According to [22], nitrogen is a key nutrient for cereals; however, it is only fully valorized if sufficient quantities of P and K are available. Moreover, [23] reports that cereal nutrition in general, and maize nutrition in

particular, is efficient when the two macronutrients P and K are in sufficient quantities in the soil solution. This statement reflects Mitscherlich's law of complementarity between major elements.

### **3.2.3. Correlation between parameters studied**

The response to maize fertilization differs for the vegetative and production phases. Indeed, while the effect of fertilization is weak, almost non-existent for growth parameters, maximum doses are defined for cob mass and seed number, suggesting that yield is still not directly correlated with vegetative plant growth. [24] justifies this lack of correlation between yield and vegetative growth parameters in rice. No positive correlation was found between vegetative and production parameters in this study of maize. The low production of the control soils can be attributed to the poor distribution of rainfall during the crop cycle. Indeed, this year's capricious rainfall, with a pocket of drought during the heading and grain formation period, justifies the low level of production [17]. Furthermore, the low level of performance of the lines obtained by successive self-fertilizations is linked to their loss of vigor and productivity compared with the EV8728 parent variety.

This variability and the uncertainty of rainfall in relation to climate change would partly explain the lack of correlation between vegetation and production parameters. In addition, on unfertilized control plots, regular bush fires were at the root of a loss of organic matter and nutrients, causing a reduction in biomass, microbial activity and phosphorus unavailability, which together led to a significant drop in crop yields [25].

Analysis of the correlation matrix showed a strong correlation between male and female flowering. Our results concur with those of [26], who showed that the duration of the sowing-flowering cycles (male and female) are positively and significantly correlated. However, female flowering is moderately negatively correlated with plant crown circumference.

## **CONCLUSION**

At the end of this experimental study, which involved assessing the N, P and K requirements of three maize lines obtained by gamma irradiation after five generations of self-fertilization, the EV8728 control gave better results in terms of both growth and yield parameters than the irradiated lines. In addition, after applying N, P and K at various increasing doses to these lines, we obtained variable results in terms of the evaluation of the various parameters. However, only nitrogen applied at low doses gave the greatest heights in terms of plant height. It would therefore be necessary to carry out this experimental study by applying these three (3) fertilisers combined at different doses in order to better understand the veracity of this experimental study, and also to determine the proportion of mineral elements taken up by each plant through analyses such as foliar diagnosis.

## REFERENCES

- [1] Frédéric H. (2020). World maize production. Available online at: <http://www.wikiagri.fr>. Accessed 04/08/2020.
- [2] FAOSTAT (2018). <http://www.fao.org/faostat/fr/data/QC>. Accessed October 20, 2020.
- [3] Laopé A, Mariame C, Roger B, Tah V, Kouadio A. (2020). Response of two local varieties of maize (*Zea mays* L.) to two types of fertilization in post-floral water deficit conditions in sudanian zone of Côte d'Ivoire. *International journal of Biological and Chemical Sciences* 14(1) 55-68.
- [4] FAOSTAT (2015). <http://www.fao.org/faostat/fr/data/QC>. Accessed December 20, 2020
- [5] Blassonny R. (2013). Ivory grain, <http://www.ivoiregion.net/index.php/lanouvelle/726-germination-le-mais-veut-damer-le-pion-au-coton>
- [6] Charcosset A, Gallais A. (2009). Emergence and development of the concept of hybrid varieties in maize. *Le Sélectionneur Français*, 60 : 21-30.
- [7] Deffan P, Akanvou L, Akanvou R, Nemlin G, Kouamé L. (2015). Morphological and nutritional evaluation of local and improved varieties of maize (*Zea mays* L.) produced in Côte d'Ivoire. *Afrique SCIENCE* 11(3) 181 - 196.
- [8] Maltas A, Charles R, Bovet V, Sokrat S. (2012). Long-term effect on crop yield and nitrogen fertilization. *Rech. Agron. Suisse*, 3, 156-163.
- [9] Yira Y. (2008). Evaluation of different manuring formulas for maize in cropping systems in the Guena terroir, Kenedougou province, in the western cotton zone of Burkina Faso. Dissertation for the diploma of rural development engineer, option: agronomy, Université Polytechnique de Bobo-Dioulasso, Burkina Faso, 48p.
- [10] Gros A. (1976). *Engrais : Guide pratique de la fertilisation*, 7th edition, Maison Rustique, Paris, France, 239p.
- [11] FAO. (1987). *Maize agronomy - Improvement and production of maize, sorghum and millet*. Rome, 2: 159-163.
- [12] Terre-net Média. (2020). Fertilisation du maïs. Les besoins nutritionnels de la culture, 2p
- [13] Bambara F. (2012). Optimisation de la fertilisation azotée du maïs en culture pluviale dans l'ouest du Burkina Faso: utilisation du modèle agronomique DSSAT. Mémoire de fin de cycle, Option: Agronomie, IDR /UPB, Bobo Dioulasso, Burkina Faso, 60 p.
- [14] Effect of irradiation on the field behaviour of maize (*Zea mays* L.) plants M1. Diploma thesis in plant biology and ecology, Faculty of Science, OPTION: Plant Physiology, University of Antananarivo, Madagascar, 50p.
- [15] Abdul M, Asif U, Habib A, Zahir M. (2010). Gamma irradiation effects on some growth parameters of *Lepidium sativum* L. *Journal of Agricultural and Biological Science*, 5(1): 39-42.



- [16] Abou-Zeid HM, Abdel-Latif SA. (2014). Effect of gamma irradiation on biochemical and antioxidant defense system in wheat (*Triticum aestivum*) seedlings. *int J adv Res*, 2 (8): 287-300.
- [17] Soro D, Ayolié K, Gohi Bi Z, Yao Y, Konan-Kan K, Sidiki B, Téhua A, Yatty K. (2015). Impact of organic fertilization on maize (*zea mays* L.) production in a ferralitic soil of center west Côte d'Ivoire, *journal of experimental biology and agricultural Sciences*, 3 (6): 556-565.
- [18] Soro D, Yeo L, Konate Z, Guei A, Zro-Bi G. (2021). When termites' waste products highlight a fundamental law of fertilization under rainfed rice cultivation in West Cote d'Ivoire. *European Journal of Agriculture and Food Sciences*, (3) :53-59.
- [19] Nyembo K, Useni S, Mpundu M, Bugeme M, Kasongo L, Baboy L. (2012). Effects of varying doses of inorganic fertilizers (NPKS and Urea) on yield and economic profitability of new *Zea mays* l varieties in Lubumbashi, Southeastern DR Congo. *Journal of Applied Biosciences*, 59: 4286-4296 SSN 1997-5902.
- [20] Ziadi, NB, Gagnon P, Rochette D, Angers M, Chantigny. (2006). Nitrogen use efficiency and N<sub>2</sub>O emission reduction in corn receiving mineral fertilizers. Project report, 12 p.
- [21] Brassard M. (2007). Development of diagnostic tools for grain corn nitrogen nutrition for optimal nitrogen fertilizer management. Master's thesis. Université de Laval, 105 p.
- [22] Elalaoui, A.C. (2007). Fertilisation minérale des cultures: les éléments fertilisants majeurs (Azote, Potassium, Phosphore). *Bulletin mensuel d'information et de liaison du PNTTA n°155*, 4 p.
- [23] Tondoh J, Kouamé F, Guéi M, Sey B, Koné A, Gnessougou N. (2015). Ecological changes induced by full-sun cocoa farming in Côte d'Ivoire. *Global ecology and conservation*, 3 :575-595.
- [24] Grantz D, Farrar J. (1999). Acute exposure to ozone inhibits rapid carbon translocation from source leaves of pima cotton. *Journal of Experimental botany* 50, 1235-1262.
- [25] Moussa A, Salako V, Gbemavo D, Zaman-Allah, Kakaï R, Bakasso Y. (2018). Agromorphological performance of local and improved maize varieties in southwest Niger. *African Crop Science Journal* 26 (2): 157-173